



Low NOx High Velocity–High Turndown Inputs to 25 million Btu/hr

HiRAMs are particularly applicable to aluminum melters, ladle heaters, soaking pits, rotary kilns, heat treat furnaces, and dryers: Any installation where high velocity entrainment, penetration, and recirculation can benefit temperature uniformity and thermal efficiency.

A 4575 HiRAM Burner's true high velocity results from exceptionally high Btu/hr input rates relative to its reduced tile discharge area. Velocities ranging from 500 to 750 feet per second (340 to 510 mph) drive heat into a furnace load, creating tremendous momentum while entraining and recirculating 7-10 cubic feet of furnace gases for every cubic foot of burner product.

HiRAMs are suitable for furnace temperatures up to 2400 F. They can be used with preheated air up to 600 F. The reduced tile discharge opening also protects burner internals from radiant heat and from melting furnace splash. Standard burners include 3000 F dense castable tiles.

Burner tile installation should be made in accord with instructions on Supplement DF-M1 for hard refractory lined furnaces or DF-M2 for fiber lined furnaces.

The Hi-RAM burners can be used with a variety of control systems including pressure-balanced or electronic fuel/air ratio systems. The gas pressure requirement is approximately 0.7

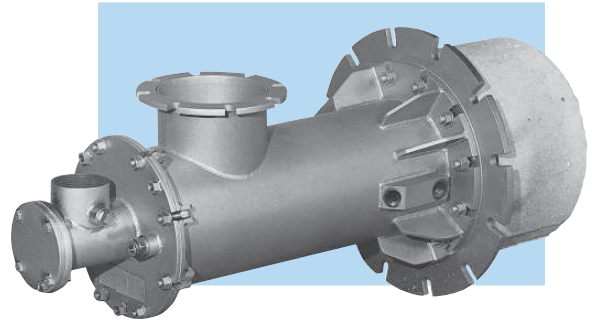

that of the combustion air when firing on stoichiometric ratio. System pressure drops should be checked to make sure that adequate gas pressure will be available at the burner. It is imperative that the limiting orifice gas valve be placed within 5 pipe diameters of the burner gas connection. HiRAM burners are not designed for fuel rich operation. Prolonged fuel rich operation may damage the burner.

A gas pilot is preferred. Direct spark ignition is satisfactory. Torch lighting is not recommended because of high tile pressures. See Sheet 4000-2 for general details concerning direct spark ignition.

4575 burners (except the -8-A and -14 sizes) are available in dual-fuel (gas/light oil) models--see Bulletin 6575.

HiRAMs are an extension upward of North American's line of Tempest® Burners. For capacities less than 3 000 000 Btu/hr, consider 4441 or 4445 Tempest Burners.

Flame Detection: UV only, flame rods not recommended.

COMBUSTION AIR CAPACITIES scfh

(for Btu/hr, multiply by 100)

Burner designation	combustion air pressure drop across the burner in osi					Flame length (stoichiometric ratio, 16 osi air)
	0.2	1	4	9	16	
4575-8-A	4 400	9 400	19 600	31 000	41 500	5'
4575-8-B	5 250	13 300	29 500	43 600	62 000	6'
4575-9	9 200	21 000	44 000	64 000	89 000	9'
4575-10-A	10 600	23 800	47 600	72 500	101,000	9'
4575-10-B	12 500	28 000	57 500	85 000	119 000	10'
4575-12	19 100	42 700	81 500	118 000	164 000	10'
4575-14	34 000	64 000	124 000	188 000	250 000	17'

Burner designation	Maximum excess air rates in % ^①			Air capacities not burning, scfh (use to size blowers) 16 osi	Pilot set	Direct spark igniter	approx. net weight pounds
	combustion air pressure, osi						
	1	9	16				
4575-8-A	325	400	350	55 000	4011-12	4055-E	195
4575-8-B	650	500	750	81 000	4011-12	4055-E	195
4575-9	800	900	1200	116 000	4011-12	4055-E	200
4575-10-A	675	800	900	145 000	4011-12	4055-E	280
4575-10-B	1100	1300	1200	177 000	4011-12	4055-E	280
4575-12	1500	1200	1000	199 000	4011-12	4055-E	280
4575-14	1200	1200	1200	303 000	4011-12	4055-E	695

① Do not operate fuel rich.

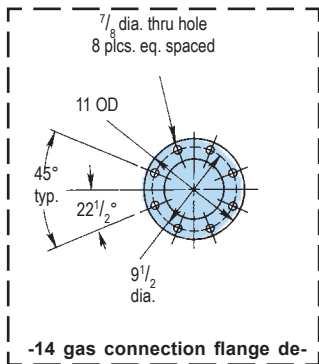

Gas connection is furnished with slotted flange and swing-away bolts for quick disconnect. Swing-away can be specified as an extra for slotted main air flange. SW style air inlet flange (optional) is also slotted--see parts list, Sheet 6575-2.

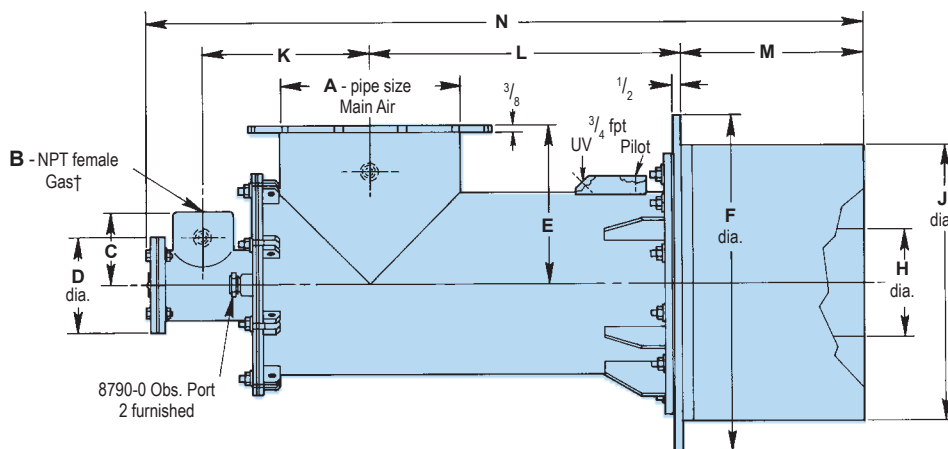
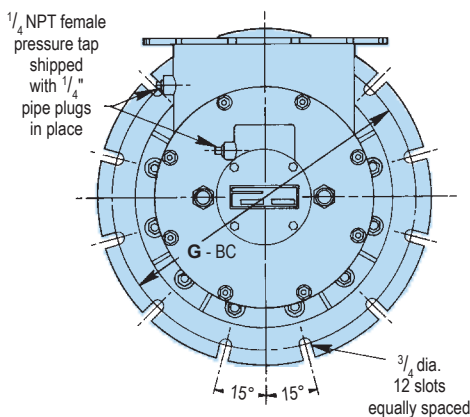
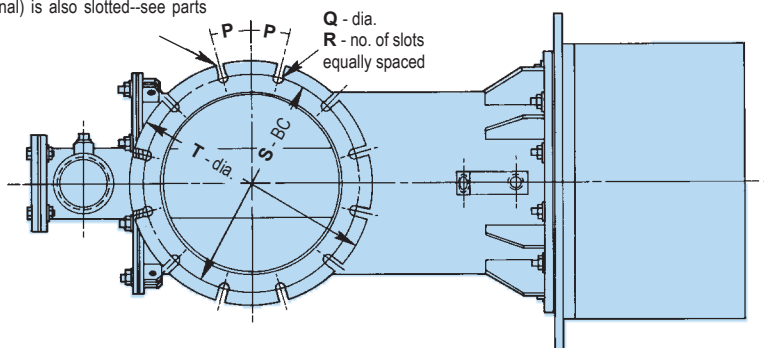

dimensions in inches and degrees

Burner designation	A	B	C	D	E*	F	G	H	J	K	L	M	N	P°	Q	R	S	T
4575-8-A	6	2 1/2	3 3/4	5 1/4	7 1/2	18	16	4 1/16	14	9 1/2	16 5/8	9	38 5/8	22 1/2	9/16	8	7 1/8	9
4575-8-B	6	2 1/2	3 3/4	5 1/4	7 1/2	18	16	4 5/8	14	9 1/2	16 5/8	9	38 5/8	22 1/2	9/16	8	7 1/8	9
4575-9	8	2 1/2	3 3/4	5 1/4	7 1/2	18	16	5 5/16	14	9 1/2	16 5/8	9	38 5/8	22 1/2	9/16	8	10	11
4575-10-A	10	3	4 3/4	6 1/4	10 1/2	22	20	6 1/4	18	11 1/16	20 5/8	12	47 3/8	15	3/4	12	12 1/4	14
4575-10-B	10	3	4 3/4	6 1/4	10 1/2	22	20	6 1/2	18	11 1/16	20 5/8	12	47 3/8	15	3/4	12	12 1/4	14
4575-12	12	3	4 3/4	6 1/4	10 1/2	22	20	7	18	11 1/16	20 5/8	12	47 3/8	15	3/4	12	14 1/4	16
4575-14	14	6†	12 5/16	8 1/4	12	26	24	9 3/4	22	16	24 3/8	18	64	15	3/4	12	16 1/4	18

† 6" - 150 lb ANSI Gas Inlet (see detail in upper left-hand corner).

* SW style inlet (optional--see parts list, Sheet 6575-2) will add 4 3/8" to the dimension "E" shown.

To order, specify: 4575-(code)-(A or B if applicable) Burner complete (specify Arrangement Designators--see sketch).

Example: 4575-9 Burner complete, Arrangement 4a

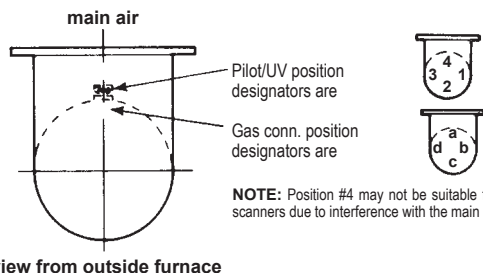

view from outside furnace

Arrangement Designators are specified relative to the main air connection at 12 o'clock and should be listed for **pilot/UV and gas connection in that order.**

Good practice dictates that the pilot/UV **NOT** be on the bottom of the burner.

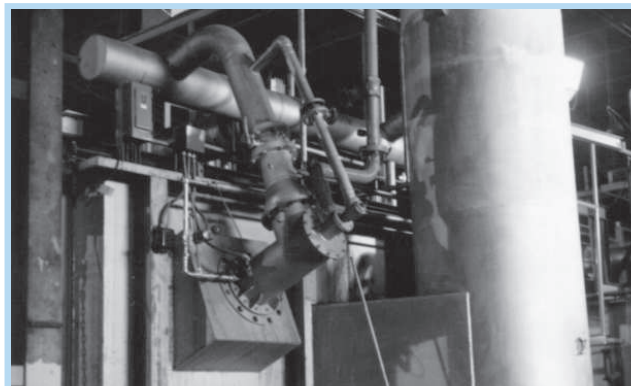

HIRAM® burners on a melting furnace provide performance and efficiency improvements without requiring the expense of heat recovery.

WARNING: Situations dangerous to personnel and property may exist with the operation and maintenance of any combustion equipment. The presence of fuels, oxidants, hot and cold combustion products, hot surfaces, electrical power in control and ignition circuits, etc., are inherent with any combustion application. Parts of this product may exceed 160F in operation and present a contact hazard. Fives North American Combustion, Inc. urges compliance with National Safety Standards and insurance Underwriters recommendations, and care in operation.